

30,000 - 140,000 BTU/HR Heaters For:

- Loading Docks
- Warehouses
- Factory Production / Assembly Areas
- Pole Barns, Farm Buildings
- Animal Comfort (pens, animal stalls, etc.)
- Auto & Truck Repair Shops
- Sporting Arenas
- Public Entranceways

America's Most Complete Line Of Infrared Heaters!

HIGHLY EFFICIENT AND COST EFFECTIVE RADIANT HEAT.

- **Efficient Infrared Heat** - Directly heats people and objects which in turn heats surrounding air to desired temperature
- **Durable** - Rugged construction
- **Instant Heat** - Adjustable thermostat for individually controlled warmth
- **Convenient** - Easy to operate and install
- **Instant Heat** - Quiet, clean, odor-free operation
- **Maintenance Free** - No moving parts to service
- **CSA Certified**
- **Limited 1-Year Warranty** - On gas control
- **Pro-Rated 10-Year Warranty** - On burner assembly

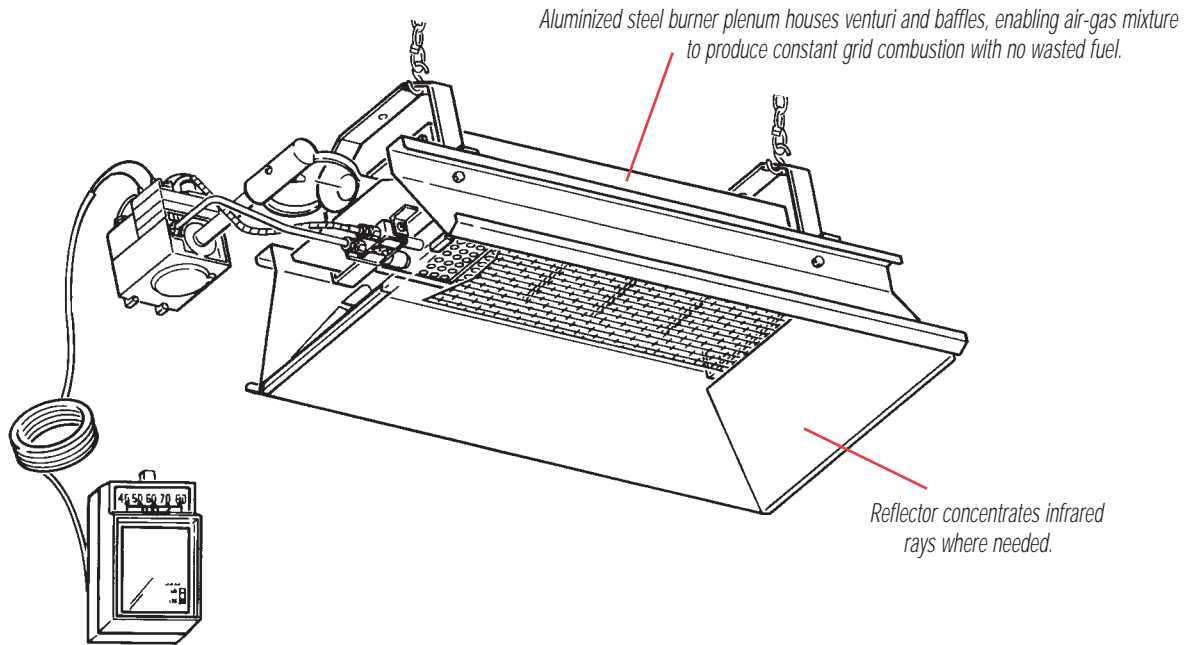

SPECIFICATIONS & TECHNICAL DATA

SERIES	MODEL NUMBER	BTU/HR	MOUNTING CLEARANCE TO COMBUSTIBLES				TOTAL DIMENSIONS L x W x H (INCHES)	SHIPPING WEIGHT (LBS)	TYPICAL MOUNTING HEIGHT	CONTROL SYSTEMS AVAILABLE		
			TOP	SIDES	BACK	BELOW				SUFFIX	DESCRIPTION	GAS
4000	4030	30,000	30"	30"	30"	54"	30 1/4" x 19 1/4" x 12	25	10'-12'	DSP-5	Automatic Spark Ignition on pilot with safety burner shutoff, 24VAC control with intermittent pilot. (Pilot is off when heater is off) Transformer 120V/24V shipped loose with heater.	Natural
	4040	40,000	34"	30"	30"	68"	30 1/4" x 19 1/4" x 12	25	10'-12'			
	8050	50,000	36"	30"	30"	78"	45 1/4" x 19 1/4" x 12	34	13'-15'			
8000	8060	60,000	40"	30"	30"	84"	45 1/4" x 19 1/4" x 12	34	13'-15'	LA-5	Automatic Spark Ignition on pilot with safety burner shutoff, 24VAC control with intermittent pilot. (Pilot is off when heater is off) Transformer 120V/24V shipped loose with heater.	Propane
	8070	70,000*	40"	30"	30"	84"	45 1/4" x 19 1/4" x 12	34	13'-15'			
9000S	9080	80,000	46"	40"	40"	104"	60 1/2" x 21 1/2" x 11	49	15'-18'			
	9090	90,000	46"	46"	46"	114"	60 1/2" x 21 1/2" x 11	49	15'-18'			
	9100S	100,000	48"	46"	46"	118"	60 1/2" x 21 1/2" x 11	49	15'-28'	PP	Power pile (self-generating) millivolt control. No outside electrical source is required to turn heater on and off. Manually lit pilot. Safety shutoff on pilot and burner. Power pile thermostat shipped loose with heater.	Natural / Propane
9100	9100	100,000	44"	40"	40"	104"	82 1/2" x 21 1/2" x 11	61	18'-higher			
	9120	120,000	46"	46"	46"	114"	82 1/2" x 21 1/2" x 11	61	18'-higher			
	9140	140,000*	46"	46"	46"	114"	82 1/2" x 21 1/2" x 11	61	18'-higher			

Optional controls available, contact factory for details.

NOTE: All 4000 series heaters are shipped with a 40,000 BTU/HR burner orifice. An additional orifice is included to convert heater to 30,000 BTU/HR.

NOTE: All 8000 series heaters are shipped with 60,000 BTU/HR orifices. Additional orifices are included to convert to 50,000 and 70,000* BTU/HR.

NOTE: All 9000S series heaters are shipped with 100,000 BTU/HR orifices. Additional orifices are included to convert heater to 80,000 and 90,000 BTU/HR.

NOTE: All 9100 series heaters are shipped with 120,000 BTU/HR orifices. Additional orifices are included to convert to 100,000 and 140,000* BTU/HR.

* 70,000 and 140,000 BTU/HR heaters available only in natural gas models.

DO NOT use this in sleeping quarters, mobile homes, or recreational vehicles.



CSA Certified