



Model HST45
45,000 BTU/HR Heater For:

- Residential Garages
- Small Shops
- Restaurant Decks & Patios
- Entrance Ways
- Golf Driving Ranges
- Farm Buildings
- Ski Lodges
- Bus & Smoking Shelters
- Green Houses

Designed For Indoor And Outdoor Use.

EFFICIENT AND EFFECTIVE LOW-INTENSITY INFRARED RADIANT HEAT.

- Compact – 3" Aluminized Steel U-Tube Design
- Provides Uniform Heat Distribution
- Polished Aluminum Deep-Dish Reflector
- Burner And Tube/Reflector Assembly Shipped In Separate Cartons To Eliminate Shipping Damage

Easy Installation

- Simply:
 1. Hang Tube/Reflector Assembly
 2. Bolt On Burner
 3. Run Gas, Electric And Vent
- Horizontal Or Angle Mount
- 10' Overall Length
- Air Intake And Exhaust Collars Attached
- Total Weight: 91 lbs.

Operating Flexibility

- Includes Gas Conversion Kit
- Commercial And Residential Approved
- Indoor And Outdoor Approved
- 3-Year Warranty On Parts & Burner
- 10-Year Warranty On Tube

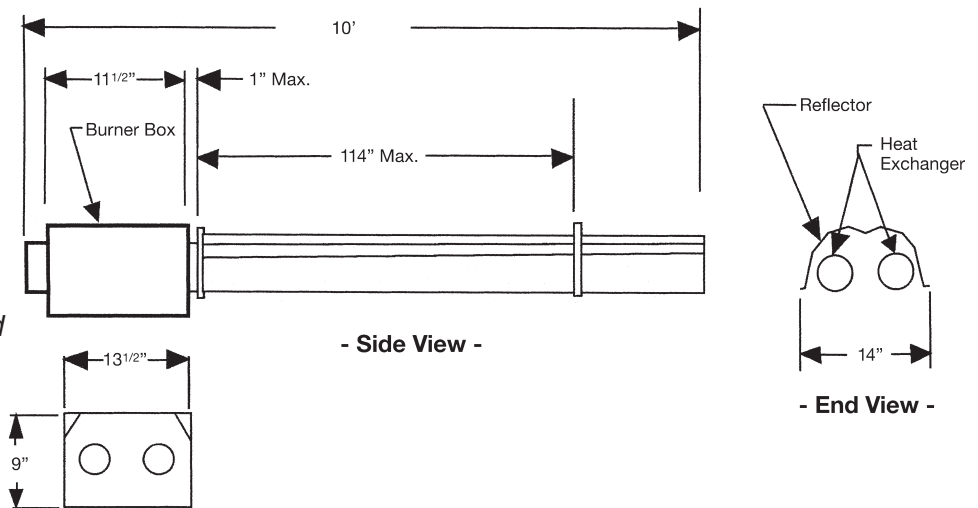

TECHNICAL DATA	HST45NG	HST45LP
Stock Number	F108850	F108851
Electrical Rating	120VAC, 60Hz, single phase, 1 amp	120VAC, 60Hz, single phase, 1 amp
Electrical Connection	3 pin moulded plug	3 pin moulded plug
Gas Inlet Connection	1/2" male NPT	1/2" male NPT
Gas Inlet Pressure		
MINIMUM	5.0" w.c.	11.0" w.c.
MAXIMUM	10.5" w.c.	13.5" w.c.
Manifold Pressure	4.0" w.c.	10.0" w.c.
Weight	91 lbs.	91 lbs.
Length	10'	10'

MOUNTING CLEARANCES	HORIZONTAL	45° ANGLE
Top	5"	5"
Bottom	54"	36"
Reflector Side	24"	4"
Tube Side	24"	38"
Reflector End	6"	6"
Burner End	24"	24"

VENTING SPECIFICATIONS	
Length	5 feet
MINIMUM	25 feet
MAXIMUM	
Flue Pipe	3.0" diameter
Vent Pipe	3.0" diameter

